

STRAIGHT SPUR GEARS

HUBSIDE

Pressure angle 20°

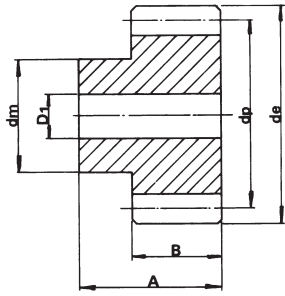

MATERIAL: C 45 - UNI 7845

TOOTH WIDTH "B" for:

MODULE 1	=	15 mm.
MODULE 1.5	=	17 mm.
MODULE 2	=	20 mm.
MODULE 2.5	=	25 mm.
MODULE 3	=	30 mm.
MODULE 4	=	40 mm.
MODULE 5	=	50 mm.
MODULE 6	=	60 mm.

TOTAL HEIGHT "A" for:

MODULE 1	=	25 mm.
MODULE 1.5	=	30 mm.
MODULE 2	=	35 mm.
MODULE 2.5	=	40 mm.
MODULE 3	=	50 mm.
MODULE 4	=	60 mm.
MODULE 5	=	75 mm.
MODULE 6	=	80 mm.

Z	MODULE 1				MODULE 1.5				MODULE 2				MODULE 2.5			
	d _e	d _p	d _m	D ₁	d _e	d _p	d _m	D ₁	d _e	d _p	d _m	D ₁	d _e	d _p	d _m	D ₁
12	14	12	9	5	21.0	18.0	14	8	28	24	18	10	35.0	30.0	22	10
13	15	13	10	5	22.5	19.5	14	8	30	26	19	10	37.5	32.5	25	10
14	16	14	10	5	24.0	21.0	18	8	32	28	20	10	40.0	35.0	28	10
15	17	15	12	6	25.5	22.5	18	8	34	30	22	10	42.5	37.5	30	10
16	18	16	13	6	27.0	24.0	20	8	36	32	24	10	45.0	40.0	32	12
17	19	17	14	8	28.5	25.5	20	8	38	34	25	10	47.5	42.5	35	12
18	20	18	15	8	30.0	27.0	20	8	40	36	25	10	50.0	45.0	35	12
19	21	19	15	8	31.5	28.5	20	8	42	38	25	10	52.5	47.5	35	12
20	22	20	16	8	33.0	30.0	25	8	44	40	30	10	55.0	50.0	40	14
21	23	21	16	8	34.5	31.5	25	10	46	42	30	12	57.5	52.5	40	14
22	24	22	18	8	36.0	33.0	25	10	48	44	30	12	60.0	55.0	45	14
23	25	23	18	8	37.5	34.5	25	10	50	46	30	12	62.5	57.5	45	14
24	26	24	20	8	39.0	36.0	25	10	52	48	35	12	65.0	60.0	45	14
25	27	25	20	8	40.5	37.5	25	10	54	50	35	12	67.5	62.5	50	14
26	28	26	20	8	42.0	39.0	30	12	56	52	40	12	70.0	65.0	50	14
27	29	27	20	8	43.5	40.5	30	12	58	54	40	12	72.5	67.5	50	14
28	30	28	20	8	45.0	42.0	30	12	60	56	40	12	75.0	70.0	50	14
29	31	29	20	8	46.5	43.5	30	12	62	58	40	14	77.5	72.5	50	14
30	32	30	20	8	48.0	45.0	30	12	64	60	40	14	80.0	75.0	55	16
31	33	31	25	10	49.5	46.5	35	12	66	62	45	14	82.5	77.5	55	16
32	34	32	25	10	51.0	48.0	35	12	68	64	45	14	85.0	80.0	55	16
33	35	33	25	10	52.5	49.5	35	12	70	66	45	14	87.5	82.5	55	16
34	36	34	25	10	54.0	51.0	35	12	72	68	45	14	90.0	85.0	55	16
35	37	35	25	10	55.5	52.5	35	12	74	70	45	14	92.5	87.5	60	16
36	38	36	25	10	57.0	54.0	35	12	76	72	45	14	95.0	90.0	60	16
37	39	37	25	10	58.5	55.5	40	12	78	74	50	14	97.5	92.5	60	16
38	40	38	25	10	60.0	57.0	40	12	80	76	50	14	100.0	95.0	60	16
39	41	39	25	10	61.5	58.5	40	12	82	78	50	14	102.5	97.5	60	16
40	42	40	25	10	63.0	60.0	40	12	84	80	50	14	105.0	100.0	70	20
41	43	41	30	10	64.5	61.5	50	14	86	82	60	16	107.5	102.5	70	20
42	44	42	30	10	66.0	63.0	50	14	88	84	60	16	110.0	105.0	70	20
43	45	43	30	10	67.5	64.5	50	14	90	86	60	16	112.5	107.5	70	20
44	46	44	30	10	69.0	66.0	50	14	92	88	60	16	115.0	110.0	70	20
45	47	45	30	10	70.5	67.5	50	14	94	90	60	16	117.5	112.5	70	20
46	48	46	30	10	72.0	69.0	50	14	96	92	60	16	120.0	115.0	70	20
47	49	47	30	10	73.5	70.5	50	14	98	94	60	16	122.5	117.5	80	20
48	50	48	30	10	75.0	72.0	50	14	100	96	70	16	125.0	120.0	80	20
49	51	49	30	10	76.5	73.5	50	14	102	98	70	16	127.5	122.5	80	20
50	52	50	30	12	78.0	75.0	50	14	104	100	70	16	130.0	125.0	80	20
51	53	51	40	12	79.5	76.5	60	15	106	102	70	20	132.5	127.5	90	20
52	54	52	40	12	81.0	78.0	60	15	108	104	70	20	135.0	130.0	90	20
53	55	53	40	12	82.5	79.5	60	15	110	106	70	20	137.5	132.5	90	20
54	56	54	40	12	84.0	81.0	60	15	112	108	70	20	140.0	135.0	90	20
55	57	55	40	12	85.5	82.5	60	15	114	110	70	20	142.5	137.5	90	20
56	58	56	40	12	87.0	84.0	60	15	116	112	70	20	145.0	140.0	100	20
57	59	57	40	12	88.5	85.5	60	15	118	114	70	20	147.5	142.5	100	20
58	60	58	40	12	90.0	87.0	60	15	120	116	70	20	150.0	145.0	100	20
59	61	59	40	12	91.5	88.5	60	15	122	118	70	20	152.5	147.5	100	20
60	62	60	40	12	93.0	90.0	60	15	124	120	70	20	155.0	150.0	100	20
61	63	61	50	12	94.5	91.5	70	20	126	122	80	20				
62	64	62	50	12	96.0	93.0	70	20	128	124	80	20				
63	65	63	50	12	97.5	94.5	70	20	130	126	80	20				
64	66	64	50	12	99.0	96.0	70	20	132	128	80	20				
65	67	65	50	12	100.5	97.5	70	20	134	130	80	20				
66	68	66	50	12	102.0	99.0	70	20	136	132	80	20				
67	69	67	50	12	103.5	100.5	70	20	138	134	80	20				
68	70	68	50	12	105.0	102.0	70	20	140	136	80	20				
69	71	69	50	12	106.5	103.5	70	20	142	138	80	20				
70	72	70	50	12	108.0	105.0	70	20	144	140	80	20				

STRAIGHT SPUR GEARS

HUBSIDE

Pressure angle 20°

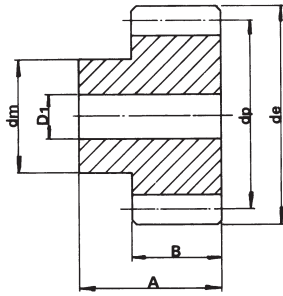

MATERIAL: C 45 – UNI 7845

TOOTH WIDTH "B" for:

MODULE 1	=	15 mm.
MODULE 1.5	=	17 mm.
MODULE 2	=	20 mm.
MODULE 2.5	=	25 mm.
MODULE 3	=	30 mm.
MODULE 4	=	40 mm.
MODULE 5	=	50 mm.
MODULE 6	=	60 mm.

TOTAL HEIGHT "A" for:

MODULE 1	=	25 mm.
MODULE 1.5	=	30 mm.
MODULE 2	=	35 mm.
MODULE 2.5	=	40 mm.
MODULE 3	=	50 mm.
MODULE 4	=	60 mm.
MODULE 5	=	75 mm.
MODULE 6	=	80 mm.

Z

12
13
14
15
16
17
18
19
20
21
22
23
24
25
26
27
28
29
30
31
32
33
34
35
36
37
38
39
40
41
42
43
44
45
46
47
48

Z	MODULE 3				MODULE 4				MODULE 5				MODULE 6			
	d _e	d _p	d _m	D ₁	d _e	d _p	d _m	D ₁	d _e	d _p	d _m	D ₁	d _e	d _p	d _m	D ₁
12	42	36	25	12	56	48	35	14	70	60	45	16	84	72	54	
13	45	39	25	12	60	52	40	14	75	65	50	16	90	78	60	
14	48	42	30	12	64	56	45	14	80	70	55	20				
15	51	45	35	12	68	60	45	14	85	75	60	20	102	90	70	
16	54	48	38	15	72	64	50	15	90	80	65	20	108	96	75	
17	57	51	42	15	76	68	50	15	95	85	70	20				
18	60	54	45	15	80	72	50	15	100	90	70	20	120	108	80	
19	63	57	45	15	84	76	60	15	105	95	70	20				
20	66	60	45	15	88	80	60	15	110	100	80	20	132	120	90	
21	69	63	45	15	92	84	70	20	115	105	80	20				
22	72	66	50	15	96	88	70	20	120	110	80	25				
23	75	69	50	15	100	92	75	20	125	115	90	25				
24	78	72	50	16	104	96	75	20	130	120	90	25	156	144	110	
25	81	75	60	16	108	100	75	20	135	125	90	25	162	150	110	
26	84	78	60	16	112	104	75	20	140	130	100	25				
27	87	81	60	16	116	108	75	20	145	135	100	25				
28	90	84	60	16	120	112	75	20	150	140	100	25				
29	93	87	60	16	124	116	75	20	155	145	100	25				
30	96	90	60	16	128	120	75	20	160	150	100	25				
31	99	93	70	20	132	124	80	20								
32	102	96	70	20	136	128	80	20								
33	105	99	70	20	140	132	80	20								
34	108	102	70	20	144	136	80	20								
35	111	105	70	20	148	140	80	20								
36	114	108	70	20	152	144	80	20								
37	117	111	80	20												
38	120	114	80	20												
39	123	117	80	20												
40	126	120	80	20												
41	129	123	90	20												
42	132	126	90	20												
43	135	129	90	20												
44	138	132	90	20												
45	141	135	90	20												
46	144	138	90	20												
47	147	141	90	20												
48	150	144	100	20												

STRAIGHT SPUR GEARS

HUBLESS

Pressure angle 20°

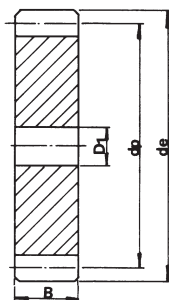

TOOTH WIDTH "B" for:

- MODULE 1 = 15 mm.
- MODULE 1.5 = 17 mm.
- MODULE 2 = 20 mm.
- MODULE 2.5 = 25 mm.
- MODULE 3 = 30 mm.
- MODULE 4 = 40 mm.
- MODULE 5 = 50 mm.
- MODULE 6 = 60 mm.

MATERIAL: C 45 – UNI 7845

Z

55
57
60
65
70
72
75
76
78
80
85
90
95
97
100
110
114
120
127

MODULE 1				MODULE 1.5				MODULE 2				MODULE 2.5			
d _e	d _p	d _m	D ₁	d _e	d _p	d _m	D ₁	d _e	d _p	d _m	D ₁	d _e	d _p	d _m	D ₁
												167.5	162.5		20
												180.0	175.0		20
74	72		12	111.0	108.0		20	148	144		20	185.0	180.0		20
77	75		12	115.5	112.5		20	154	150		20	192.5	187.5		20
78	76		12	117.0	114.0		20	156	152		20	195.0	190.0		20
82	80		12	123.0	120.0		20	164	160		20	205.0	200.0		25
87	85		12	130.5	127.5		20	174	170		20	217.5	212.5		25
92	90		12	138.0	135.0		20	184	180		20	230.0	225.0		25
97	95		12	145.5	142.5		20	194	190		20	242.5	237.5		25
102	100		12	153.0	150.0		20	204	200		20	255.0	250.0		25
112	110		12	168.0	165.0		20	224	220		20	280.0	275.0		25
116	114		12	174.0	171.0		20	232	228		20	290.0	285.0		25
122	120		12	183.0	180.0		20	244	240		20	305.0	300.0		25
129	127		12	193.5	190.5		20	258	254		20	322.5	317.5		25

Z

28
30
32
35
38
40
45
48
50
52
55
57
60
65
70
72
75
76
80
85
90
95
100
110
114
120
127

MODULE 3				MODULE 4				MODULE 5				MODULE 6			
d _e	d _p	d _m	D ₁	d _e	d _p	d _m	D ₁	d _e	d _p	d _m	D ₁	d _e	d _p	d _m	D ₁
												180	168		25
												192	180		25
								170	160		25	204	192		25
				160	152		25	185	175		25	222	210		25
				168	160		25	200	190		30	240	228		25
				188	180		25	210	200		30	252	240		25
				200	192		25	235	225		30				
				208	200		25	250	240		30				
156	150		25	216	208		25	260	250		30				
162	156		25	228	220		25	270	260		30				
171	165		25	236	228		25	285	275		30				
177	171		25	248	240		25	295	285		30				
186	180		25	268	260		25	310	300		30				
201	195		25	288	280		25	335	325		30				
216	210		25	308	300		25	360	350		30				
222	216		25	312	304		25	385	375		30				
231	225		25	328	320		25	390	380		30				
234	228		25	348	340		25	410	400		30				
246	240		25	368	360		25	435	425		30				
261	255		25	388	380		25	460	450		30				
276	270		25	408	400		25	485	475		30				
291	285		25	448	440		25	510	500		30				
306	300		25	464	456		25	560	550		30				
336	330		25				25	580	570		30				
348	342		25				25								
366	360		25												
387	381		25												

CAST IRON SPUR GEARS

		MATERIAL: G20 CAST IRON – UNI 5007						
Z	Module	2	2.5	3	3.5	4	4.5	5
	Bores D ₁	15	18	20	20	25	25	30
	Surface B	20	25	30	35	40	45	50
30	dp					120	135	150
	de					128	144	160
	dm					70	70	80
35	dp				122.5	140	157.5	175
	de				129.5	148	166.5	185
	dm				60	70	70	80
40	dp				140	160	180	200
	de				147	168	189	210
	dm				60	70	70	80
45	dp		112.5	135	157.5	180	202.5	
	de		117.5	141	163.5	188	211.5	
	dm		50	50	60	70	70	
50	dp	100	125		175	200	225	250
	de	104	130		182	208	234	260
	dm	40	50		60	70	70	80
60	dp			180				
	de			186				
	dm			50				

Spur Gears

Pressure angle 20°

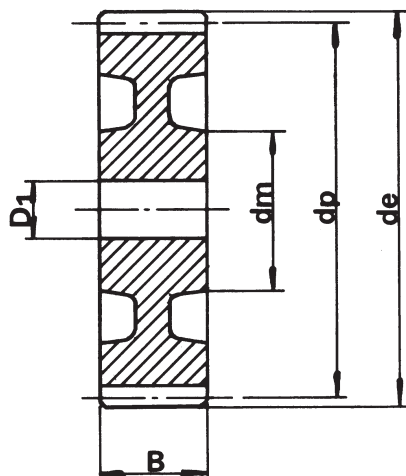

Gear till sold out

RACKS

		MATERIAL: C40 - DRAWN - STANDARDISED				
Module	Dimensions b x h		h ₀	L	kg.	
	b	h				
1	15	15	14	500	0.820	
	15	15	14	1000	1.640	
	15	15	14	2000	3.200	
1.5	17	17	15.5	500	1.000	
	17	17	15.5	1000	2.050	
	17	17	15.5	2000	4.000	
2	20	20	18	500	1.410	
	20	20	18	1000	2.750	
	20	20	18	2000	5.500	
2.5	25	25	22.5	500	2.100	
	25	25	22.5	1000	4.500	
	25	25	22.5	2000	9.000	
3	30	30	27	500	3.100	
	30	30	27	1000	6.500	
	30	30	27	2000	13.000	
4	30	30	26	500	3.050	
	30	30	26	1000	6.100	
	30	30	26	2000	12.500	
4	40	40	36	500	5.500	
	40	40	36	1000	11.000	
	40	40	36	2000	23.000	
5	50	50	45	500	8.300	
	50	50	45	1000	17.500	
	50	50	45	2000	35.000	
6	60	60	54	500	12.650	
	60	60	54	1000	25.500	
	60	60	54	2000	51.000	
10	80	80	70	2000	77.000	

Racks

Pressure angle 20°

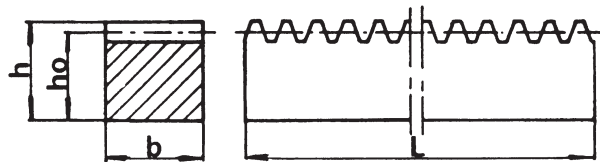

N.B. We manufacture racks from M7 to M16, on request.

BEVEL GEARS

The range of bevel gear showed in the catalogue is a selection structured according to transmission module and ratio, which is designed to meet the needs of general plant engineering and general mechanics to transmit motion among concurrent axes.

As such the range does not claim to guarantee particularly heavy-duty performance or to cater for ratio ranges that extend to cover every need.

The external configuration of the bevel gear complies with the sizing criteria as established by the DIN 3971 Standards, while the tooth geometry, corrected by displacing the profiles and by varying the taper, is a specific solution exclusive to **CHIARAVALLI Trasmissioni**.

This solution, provides special advantages since:

- the coupling conditions between the pinion and the ring gear are improved;
- a smoother motion transmission is assured;
- tooth resistance is increased;
- the undercut effect on the pinion is avoided, even in the case of high transmission ratios and pinions with a limited number of teeth.

Since these refer to a selection of gears intended to be used in a broad range of applications, **CHIARAVALLI Trasmissioni**, continuing a tradition that has now become firmly established, has defined a standardised tolerance category for the processing of the Company's range of bevel gear, which means that there is a controlled gearing gap between the wheels.

The requirements detailed in the DIN 3967 Standards adapted to the virtual teeth profile of the bevel gear and the recommendations of the DIN 3964 Standards to calculate the corresponding axial displacements for the assembly distances have been used for this purpose.

We are therefore in a position to provide the end user precise information regarding the tolerances to be adopted to define shaving adjustments to a given clearance, in accordance with the values detailed in the dimensional tables.

All the bevel gears manufactured by **CHIARAVALLI Trasmissioni** will be produced in accordance with the profile envelope procedure on modern gear cutting machines, which enables **CHIARAVALLI Trasmissioni** to ensure a satisfactory quality level thanks to the systematic checking of processing tolerances.

For this technological sector too, the equipment and the range of machines available to **CHIARAVALLI Trasmissioni** enables the Company to produce bevel gears based on a drawing and in accordance with the Customer's specifications.

STRAIGHT TEETH BEVEL GEARS

MATERIAL: C 43 - UNI 7847

M	Z	d _p	d _e	F	A	d _m	D ₁	L	V	S	L _m
1.5	16	24.0	26.12	6	18.9	20.3	8		7.10		12
	20	30.0	32.12	10	20	22	10	18	7.40	2	8.5
	25	37.5	39.62	10	23	28	10	21	11.09	2	12
	30	45.0	47.12	12	25	30	12	22.5	13.35	2.5	12
2	16	32.0	34.83	8	23.5	25.3	8		9.50		14
	20	40.0	42.83	12	25	32	10	22	10.78	3	12
	25	50.0	52.82	14	28	40	12	25	14.28	3	12.3
	30	60.0	62.83	16	30	50	12	27	17.78	3	12.8
2.5	16	40.0	43.53	10	28.1	30.3	12		11.90		15
	20	50.0	53.53	12	30.5	40	12	27	15.43	3.5	16
	25	62.5	66.00	15	33.5	50	15	30	19.48	3.5	16
	30	75.0	78.53	18	35.5	55	15	32	23.63	3.5	16
3	16	48.0	52.25	12	31.7	40.3	12		14.30		18
	20	60.0	64.24	18	35	45	15	31	16.00	4	13.6
	25	75.0	79.24	20	38	55	15	34	22.00	4	16
	30	90.0	94.24	22	40	60	20	36	28.00	4	17
3.5	16	56.0	60.95	14	36.4	45.3	16		16.60		20
	20	70.0	74.95	22	40.5	55	15	36	18.13	4.5	17
	25	87.5	92.45	26	43.5	65	20	39	23.97	4.5	18
	30	105.0	109.95	30	48	70	20	43.5	30.02	4.5	19
4	16	64.0	69.65	15	44.3	50.3	16		19.70		25
	20	80.0	85.65	25	43	60	18	38	20.74	5	18
	25	100.0	105.65	28	45	70	20	40	28.50	5	18
	30	120.0	125.65	32	48	80	20	43	35.67	5	16
4.5	16	72.0	78.38	17.5	46.3	55.3	20		21.70		25
	20	90.0	96.38	28	48	65	20	42	23.41	6	18
	25	112.5	118.80	32	50	75	20	44	31.76	6	18
	30	135.0	141.38	35	53	90	20	47	40.82	6	17
5	16	80.0	87.07	18	48.9	60.3	20		25.10		25
	20	100.0	107.07	30	50.5	70	20	44	26.86	6.5	18.5
	25	125.0	132.07	34	53.5	90	20	47	36.36	6.5	18
	30	150.0	157.07	38	56.5	110	20	50	45.97	6.5	18

Normal axis Bevel Gears

Pressure angle: 20°
in compliance with UNI 6588

Ratio - 1:1

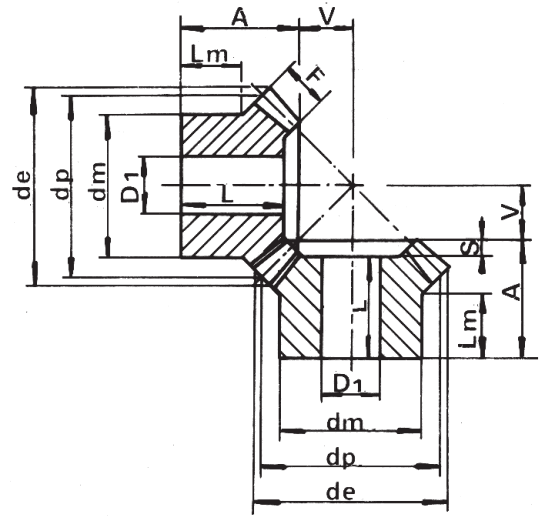

MATERIAL: C 43 - UNI 7847

M	Z	d _p	d _e	F	A	d _m	D ₁	L	V	S	L _m
1.5	16	24	26.68	8	19.5	21	10	18	16.33	1.5	11.3
	32	48	49.34	8	20.0	32	12	17	7.45	3	10
2	16	32	35.57	10	23.0	26	10	21	22.41	2	11.9
	32	64	65.78	10	25.0	40	12	21	10.21	4	10
2.5	16	40	44.47	12	27.5	34	12	25	28.38	2.5	14.4
	32	80	82.23	12	25.0	50	15	20	12.97	5	10
3	16	48	53.36	15	28.0	40	15	25	33.64	3	11.6
	32	96	98.68	15	30.0	60	15	24	15.31	6	10
3.5	16	56	62.26	18	33.5	48	15	30	38.83	3.5	14.4
	32	112	115.12	18	31.0	70	20	24	17.77	7	10
4	16	64	71.15	20	36.0	50	15	32	44.81	4	13.4
	32	128	131.57	20	32.0	80	20	24	20.42	8	10
4.5	16	72	80.05	22	39.5	60	20	35	51.00	4.5	15.4
	32	144	148.00	22	36.0	90	20	27	23.21	9	10
5	16	80	88.94	25	50.0	60	20	45	56.06	5	21.1
	32	160	164.46	25	38.0	100	20	28	25.52	10	10

Normal axis Bevel Gears

Pressure angle: 20°
in compliance with UNI 6588

Ratio - 1:2

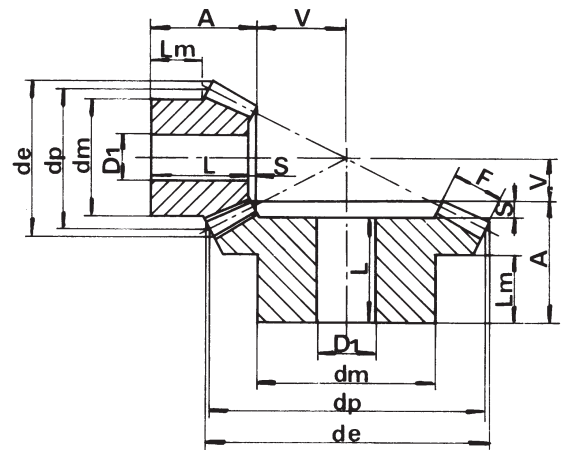

STRAIGHT TEETH BEVEL GEARS

MATERIAL: C 43 - UNI 7847

Normal axis Bevel Gears

Pressure angle: 20°
in compliance with UNI 6588

Ratio - 1:3

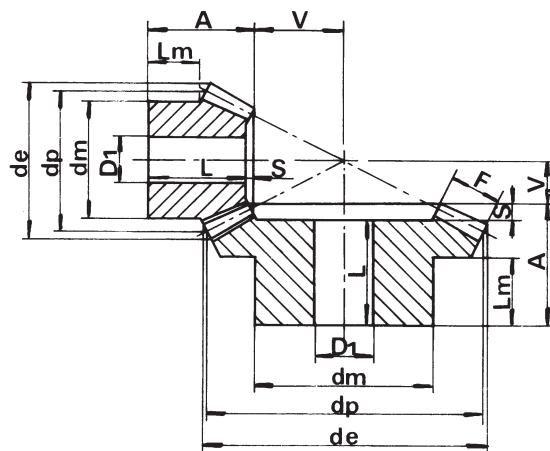

M	Z	d _p	d _e	F	A	d _m	D ₁	L	V	S	L _m
1.5	16	24	26.82	12	24	20	10	23	24.42	1	11.7
	48	72	72.95	12	20	50	12	17	7.27	3	10
2	16	32	35.80	15	28.5	26	12	27	33.26	1.5	12.4
	48	96	97.26	15	23	60	15	19	9.90	4	10
2.5	16	40	44.74	18	32	32	12	30	42.41	1.5	13
	48	120	121.58	18	26	70	20	21	12.60	5	10
3	16	48	53.69	18	32	40	15	30	54.25	2	12.1
	48	144	145.90	18	29	80	20	23	16.20	6	10
3.5	16	56	62.64	22	38	48	15	35.5	62.29	2.5	15
	48	168	170.21	22	31	90	20	24	18.48	7	10
4	16	64	71.59	25	41.5	55	20	38.5	71.23	3	15.2
	48	192	194.53	25	33	100	20	25	21.20	8	10
4.5	16	72	80.53	28	53	60	20	50	80.27	3	23.4
	48	216	218.84	28	49	100	20	40	23.93	9	18
5	16	80	89.48	35	60	60	20	57	85.61	3	22.5
	48	240	243.16	35	50	150	20	40	25.45	10	20

MATERIAL: C 43 - UNI 7847

Normal axis Bevel Gears

Pressure angle: 20°
in compliance with UNI 6588

Ratio - 1:4

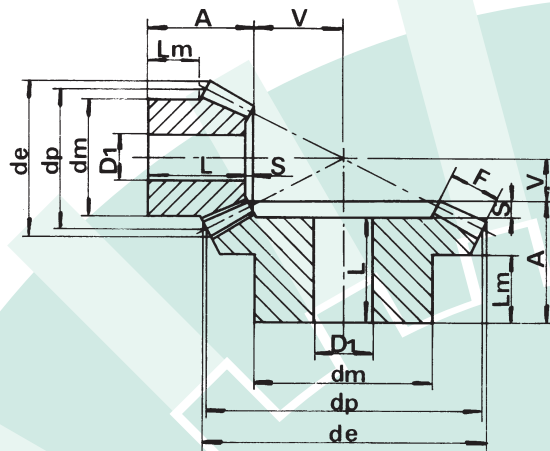

M	Z	d _p	d _e	F	A	d _m	D ₁	L	V	S	L _m
1.5	16	24	26.91	12	25	18	10	24	36.02	1	12.2
	64	96	96.73	12	22	70	15	19	8.53	3	10
2	16	32	35.88	15	24	25	12	23	49.07	1	8.2
	64	128	128.97	15	24	80	20	20	11.79	4	10
2.5	16	40	44.85	18	30.5	30	12	29	61.99	1.5	11.7
	64	160	161.21	18	29	90	20	24	13.77	5	10
3	16	48	53.82	22	34	40	15	32	74.05	2	11
	64	192	193.45	22	30	100	20	24	16.41	6	10
3.5	16	56	62.80	25	45	48	15	43	87.13	2	19.1
	64	224	225.70	25	50	100	20	43	19.32	7	22
4	16	64	71.76	30	50	50	20	48	98.21	2	18.5
	64	256	257.94	30	50	120	20	42	21.72	8	20
4.5	16	72	80.73	32	53	55	20	50.5	112.08	2.5	19
	64	288	290.18	32	53	130	20	44	24.83	9	23
5	16	80	89.70	35	58	60	20	55.5	125.06	2.5	20.6
	64	320	322.42	35	58	150	20	48	27.65	10	25

STRAIGHT TEETH BEVEL GEARS SPECIAL EXECUTION

Normal axis Bevel Gears

Pressure angle: 20°

Gleason System

Ratio - 1:1

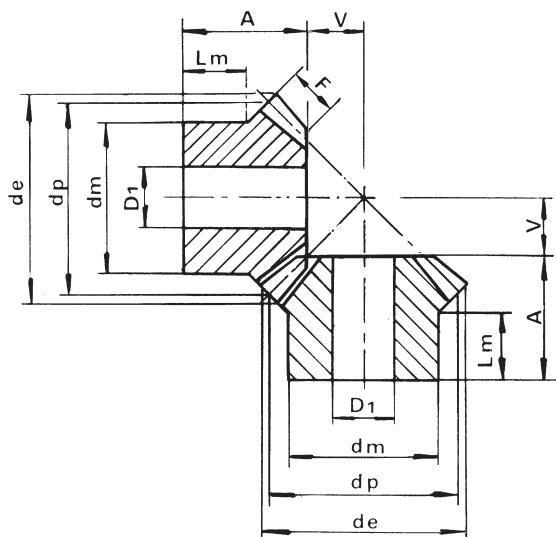

MATERIAL: C 43 - UNI 7847

M	Z	d _p	d _e	F	A	d _m	D ₁	V	L _m
1	16	16.0	17.4	4	11.2	13.3	4	4.80	6.5
	19	19.0	20.4	4	11.8	15.3	4	6.20	6.5
	22	22.0	23.4	4.7	12.8	16.3	5	7.20	6.5
	26	26.0	27.4	5.5	13.3	20.3	5	8.70	7
	30	30.0	31.4	6.4	16	20.3	5	10.00	8
1.5	16	24.0	26.1	6	18.9	20.3	8	7.10	12
	19	28.5	30.6	7	21.3	20.3	8	8.70	12
	22	33.0	35.1	7.5	22.5	25.3	8	10.50	12
	26	39.0	41.1	8.5	23.2	28.3	8	12.80	12
	30	45.0	47.1	10	27.2	30.3	12	14.80	12
2	16	32.0	34.8	8	23.5	25.3	8	9.50	14
	19	38.0	40.8	9	24.2	25.3	8	11.80	12
	22	44.0	46.8	10	27.9	30.3	12	14.10	14
	26	52.0	54.8	12	31.4	35.3	12	16.60	14
	30	60.0	62.8	13	34.1	40.3	14	19.90	17
2.5	16	40.0	43.5	10	28.1	30.3	12	11.90	15
	19	47.5	51.0	11	27.1	35.3	12	14.90	13
	22	55.0	58.5	12	30.1	45.3	16	17.90	16
	26	65.0	68.5	15	33.2	45.3	16	20.80	16
	30	75.0	78.5	16	39	50.3	16	25.00	20
3	16	48.0	52.5	12	31.7	40.3	12	14.30	18
	19	57.0	61.2	13	36	40.3	14	18.00	17
	22	66.0	70.2	15	36.9	50.3	16	21.10	17
	26	78.0	82.2	17	38.4	50.3	16	25.60	18
	30	90.0	94.2	19	43.8	60.3	20	30.20	22
3.5	16	56.0	60.9	14	36.4	45.3	16	16.60	20
	19	66.5	71.5	15	37.8	50.3	18	21.00	19
	22	77.0	81.9	17	39.1	55.3	20	24.90	18
	26	91.0	96.0	20	43.35	62.3	20	29.70	20
	30	105.0	110.0	23	47.1	70.3	20	34.90	22
4	16	64.0	69.7	15	44.3	50.3	16	19.70	25
	19	76.0	81.7	18	44.4	55.3	20	23.60	22
	22	88.0	93.7	20	45.9	60.3	20	28.10	22
	26	104.0	109.7	25	48	70.3	20	34.00	22
	30	120.0	125.7	26	54.2	80.3	20	39.80	25
4.5	16	72.0	78.4	17.5	46.3	55.3	20	21.70	25
	19	85.5	91.8	20	49	62.3	20	26.57	25
	22	99.0	105.3	22	50.1	70.3	20	31.90	25
	26	117.0	123.0	25	54.7	75.3	20	38.60	26
	30	135.0	141.4	29	60	80.3	20	45.00	28
5	16	80.0	87.1	18	48.9	60.3	20	25.10	25
	19	95.0	102.1	22	52.2	60.3	20	29.80	25
	22	110.0	117.1	24	58.2	80.3	20	35.80	30
	26	130.0	137.1	29	62.7	80.3	20	42.30	30
	30	150.0	157.1	32	68.9	80.3	20	50.10	35

STRAIGHT TEETH BEVEL GEARS

MATERIAL: C 43 – UNI 7847

M	Z	d _p	d _e	F	A	d _m	D ₁	L	V	S	L _m
1	16	16	18.1	4.3	12	13.3	4		8		7
	24	24	24.8	4.3	14.8	20.3	5	13.3	5.2	1.5	9.3
1.5	16	24	27.1	8	20.3	20.3	8		10.7		11.8
	24	36	37.2	8	24.9	28.3	8	22.7	7.1	2.2	16
2	16	32	36.2	10	25.2	25.3	8		14.8		13.8
	24	48	49.7	10	27.2	32.3	8	24.7	9.8	2.5	16
2.5	16	40	45.2	13	30.8	32.3	12		18.2		16.4
	24	60	62.1	13	34	45.3	14	30.8	12	3.2	20
3	16	48	54.3	14.5	32.4	40.3	12		22.6		16.4
	24	72	74.5	14.5	36.2	55.3	16	32	14.8	4.2	20
3.5	16	56	63.3	18	40.4	45.3	16		25.6		20.4
	24	84	86.9	18	44.2	55.3	20	40	16.8	4.2	25
4	16	64	72.4	18	46.8	50.3	16		31.2		25.4
	24	96	99.3	18	45.5	60.3	20	40	20.5	5.5	25
4.5	16	72	81.4	20	47.6	60.3	20		35.4		25.1
	24	108	111.7	20	57.8	80.3	20	51.3	23.2	6.5	35
5	16	80	90.5	24	54.1	60.3	20		37.9		25.4
	24	120	124.1	24	61.1	80.3	20	54.5	24.9	6.6	35

Normal axis Bevel Gears

Pressure angle: 20°
Gleason System

Ratio - 1:1.5

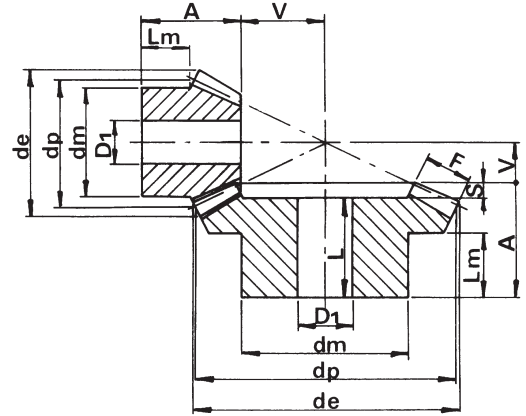

MATERIAL: C 43 – UNI 7847

M	Z	d _p	d _e	F	A	d _m	D ₁	L	V	S	L _m
1	15	15.0	17.4	5	11.9	13.3	4		10.1		6.5
	30	30.0	30.6	5	15.1	20.3	5	13.7	4.9	1.4	9
1.5	15	22.5	26.1	9	21.1	19.3	8		13.9		11.9
	30	45.0	45.9	9	25.2	32.3	8	23	6.8	2.2	16
2	15	30.0	34.8	11.5	26	25.3	8		19.0		14.1
	30	60.0	61.2	11.5	29.8	40.3	14	26.8	9.2	3	18
2.5	15	37.5	43.5	15	31.8	32.3	12		23.2		16.2
	30	75.0	76.5	15	33.7	45.3	16	30	11.3	3.7	20
3	15	45.0	52.2	17	37.3	40.3	12		28.7		19.9
	30	90.0	91.8	17	42.1	55.3	16	38	13.9	4.1	25
3.5	15	52.5	60.9	20.5	46.1	45.3	16		32.9		24.7
	30	105.0	107.1	20.5	45	60.3	20	40	16.0	5	25
4	15	60.0	69.6	22.5	48.6	50.3	20		38.4		24.6
	30	120.0	122.3	22.5	57.3	80.3	20	51.9	18.7	5.4	35
4.5	15	67.5	78.3	26	51.4	60.3	20		42.6		24.7
	30	135.0	137.6	26	60.3	80.3	20	54.3	20.7	6	35
5	15	75.0	87	30	57.6	60.3	20		46.4		25.3
	30	150.0	152.9	30	62.5	80.3	20	56	22.5	6.5	35

Normal axis Bevel Gears

Pressure angle: 20°
Gleason System

Ratio - 1:2

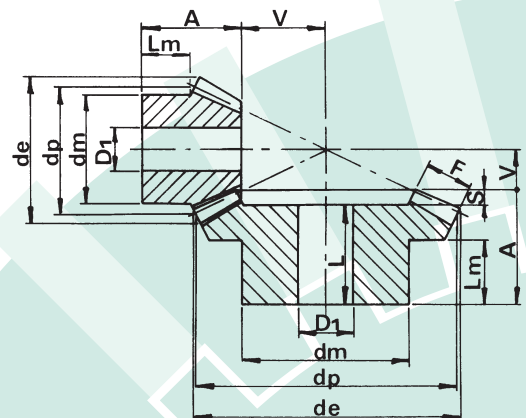

STRAIGHT TEETH BEVEL GEARS

MATERIAL: C 43 – UNI 7847

M	Z	d _p	d _e	F	A	d _m	D ₁	L	V	S	L _m
1	16	16	18.6	6.5	14.4	13.3	4		13.6		7.4
	40	40	40.4	6.5	14.8	25.3	8	13	5.2	1.8	9
1.5	16	24	27.9	11.5	24.2	20.3	8		18.8		12.3
	40	60	60.7	11.5	27.8	40.3	14	25.5	7.2	2.3	18
2	16	32	37.2	15	29.6	25.3	8		25.4		13.7
	40	80	80.9	15	32.4	45.3	16	29	9.6	3.4	20
2.5	16	40	46.4	19	38.4	32.3	12		31.6		18.5
	40	100	101.1	19	39.8	55.3	16	35.9	12.2	3.9	25
3	16	48	55.7	21.5	41.9	40.3	16		39.1		19.6
	40	120	121.4	21.5	47.9	60.3	20	44	15.1	3.9	30
3.5	16	56	65.0	22.6	49.1	45.3	20		47.9		25
	40	140	141.6	22.6	54.6	80.3	20	50	18.4	4.6	35
4	16	64	74.3	26	52.5	55.3	20		54.5		25.3
	40	170	161.8	26	57.0	80.3	20	50.5	21.0	6.5	35
4.5	16	72	83.6	30	56.3	60.3	20		60.7		24.6
	40	180	182.1	30	59.7	80.3	20	53	23.3	6.7	35
5	16	80	92.9	32	65.4	60.3	20		68.6		30.1
	40	200	202.3	32	65.7	90.3	20	58.3	26.3	7.4	40

Normal axis Bevel Gears

Pressure angle: 20°

Gleason System

Ratio – 1:2.5

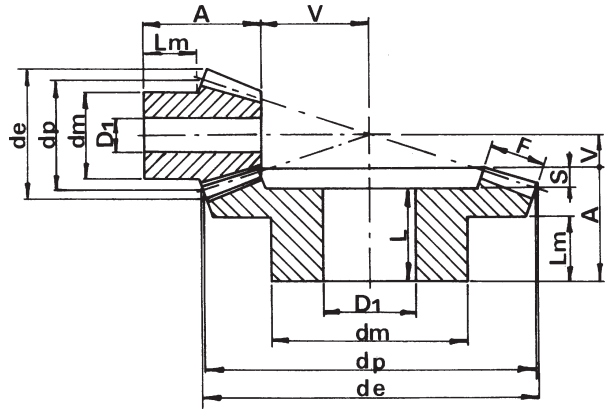

Bevel gears available till sold out

MATERIAL: C 43 – UNI 7847

M	Z	d _p	d _e	F	A	d _m	D ₁	L	V	S	L _m
1	15	15	17.7	7.1	16.6	13.3	4		15.4		9.2
	45	45	45.3	7.1	17.1	25.3	8	15.2	4.9	1.9	10
1.5	15	22.5	26.5	10.5	22.6	19.3	8		23.4		11.7
	45	67.5	68.1	10.5	29.6	45.3	14	27.2	7.4	2.4	20
2	15	30	35.4	14	28.9	25.3	8		31.1		14.2
	45	90	90.8	14	32.1	45.3	16	28.4	9.9	3.7	20
2.5	15	37.5	44.2	18	34.6	32.3	12		38.4		15.9
	45	112.5	113.4	18	39.7	60.3	20	35.3	12.3	4.4	25
3	15	45	53.0	21	41.3	40.3	16		46.7		19.7
	45	135	136.1	21	47.2	60.3	20	42	14.8	5.2	30
3.5	15	52.5	61.9	23.5	49.6	45.3	20		55.4		25
	45	157.5	158.8	23.5	54.4	80.3	20	48.6	17.6	5.8	35
4	15	60	70.7	27.5	54.3	50.3	20		62.7		25.4
	45	180	181.5	27.5	57	80.3	20	50.5	20	6.5	35
4.5	15	67.5	79.5	28.5	55.2	55.3	20		72.8		24.8
	45	202.5	204.2	28.5	63.9	90.3	20	57	23.1	6.9	40
5	15	75	88.4	33	65.3	60.3	20		79.7		30
	45	225	226.9	33	66.7	90.3	20	59.2	25.3	7.5	40

Normal axis Bevel Gears

Pressure angle: 20°

Gleason System

Ratio – 1:3

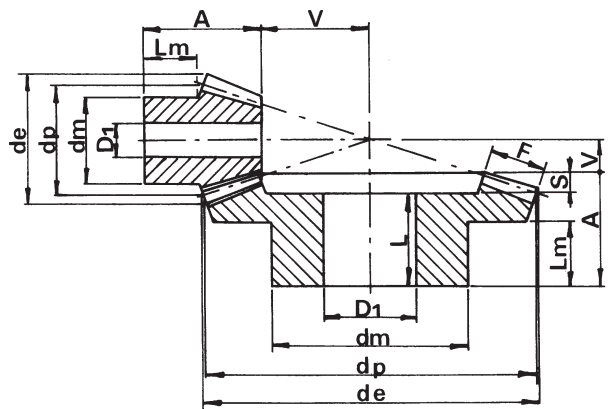

STRAIGHT TEETH BEVEL GEARS

MATERIAL: C 43 – UNI 7847

M	Z	d _p	d _e	F	A	d _m	D ₁	L	V	S	L _m
1	16	16	18.7	8.7	16.6	13.3	4		19.4		7.6
	56	56	56.3	8.7	16.7	30.3	8	14.2	5.3	2.5	10
1.5	16	24	28.1	12	24	20.3	8		30		11.5
	56	84	84.5	12	34.8	45.3	14	32	8.2	2.8	25
2	16	32	37.5	16	30.9	25.3	8		40.1		14.1
	56	112	112.6	16	37.1	55.3	16	33.3	10.9	3.8	25
2.5	16	40	46.8	20	38.9	32.3	14		50.1		17.9
	56	140	140.8	20	44.4	60.3	20	40	13.6	4.4	30
3	16	48	56.2	24	49.9	40.3	16		60.1		24.9
	56	168	169	24	52.7	80.3	20	47.5	16.3	5.2	35
3.5	16	56	65.6	25	52	25.5	20		73		25.5
	56	196	197.1	25	55.1	80.3	20	49.1	19.9	6	35

Normal axis Bevel Gears

Pressure angle: 20°

Gleason System

Ratio – 1:3.5

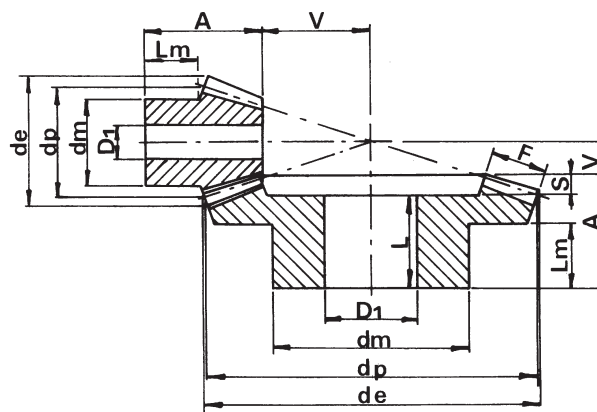

Bevel gears available till sold out

MATERIAL: C 43 – UNI 7847

M	Z	d _p	d _e	F	A	d _m	D ₁	L	V	S	L _m
1	15	15.0	17.80	9.3	17.2	13.3	4		20.8		7.7
	60	60	60.30	9.3	17.1	30.3	8	15.2	4.9	1.9	10
1.5	15	22.5	26.70	11	23	20.3	8		34.0		11.7
	60	90	90.40	11	34	50.3	16	31.2	8.0	2.8	25
2	15	30	35.60	16	31	25.3	8		44.0		14.4
	60	120	120.60	16	37.6	60.3	16	34.2	10.4	3.4	25
2.5	15	37.5	44.50	19	38.1	32.3	14		55.9		18.4
	60	150	150.70	19	44.8	60.3	20	40	13.2	4.8	30
3	15	45	53.30	23	48.1	40.3	16		66.9		24.5
	60	180.0	180.80	23	53.2	80.3	20	48.2	15.8	5	35
3.5	15	52.5	62.20	26	52.1	45.3	20		78.9		25.1
	60	210	211.00	26	60.4	90.3	20	54.4	18.6	6	40
4	15	60	71.10	30	55.1	50.3	20		89.9		23
	60	240	241.10	30	60.8	90.3	20	53	21.2	7.8	40
4.5	15	67.5	79.97	32	57	52.3	20		102.9		23
	60	270	271.24	32	62	90.3	20	53.5	24.3	8.5	40
5	15	75	88.80	34	62	55.3	20		115.7		25
	60	300.0	301.30	34	65	90.3	20	55	27.0	10	40

Normal axis Bevel Gears

Pressure angle: 20°

Gleason System

Ratio – 1:4

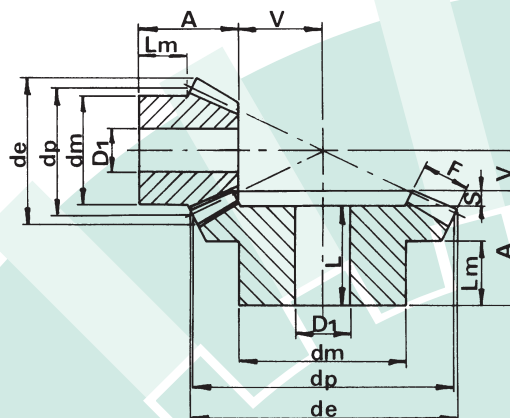

BEVEL GEARS FOR TRANSMISSIONS BETWEEN ORTHOGONAL AXES

DECLARATION OF INTENT

The **change project** of this range of bevel gears has been developed with the intention of standardising the execution of this product and reducing the number of articles carried in the catalogue.

The key aspects of the project to which we intend to draw the attention of users can be specified as follows:

- Deletion of the "special" execution bevel gears and adoption of a single execution with harmonised sizing criteria.
- Adoption of the DIN 3971 Standards to size the tooth profile and the external body of the gears.
- Systematic correction of teeth by profile displacement to eliminate the undercut effect on the pinions, to improve the slip and the specific pressure and to obtain a tooth that is better able to withstand bending stresses.
- Selection of a standardised external configuration in terms of the front embedding on the bevel gears which will be implemented only from a given module.
- Generalised increase of the surface width to achieve higher load-bearing capacities.
- Selection of the ratios and the number of teeth based solely on the normal number of the R20 range in compliance with the UNI 2016 and the DIN 323 Standards, as well as the ISO R3 and ISO R17 recommendations, with the following progressions:

Ratio	1:1 = 16 - 18 - 20 - 22 - 25 - 28 - 32
	1:2 = 16/32
	1:3 = 16/48
	1:4 = 16/64

This initiative comes within the framework of a broader critical review of the Company's products, and CHIARAVALLI Trasmissioni spa intends to implement a form of technical collaboration with customers and will take due consideration of technical advice, suggestions and assessments for which CHIARAVALLI Trasmissioni spa thanks you in advance.

BEVEL GEARS FOR TRANSMISSIONS BETWEEN ORTHOGONAL AXES

Straight teeth Bevel Gears sized in compliance with DIN 3971

Corrected toothing by profile displacement and length-wise crowning of the tooth

Pressure angle: 20°

Gear ratio = 1:1

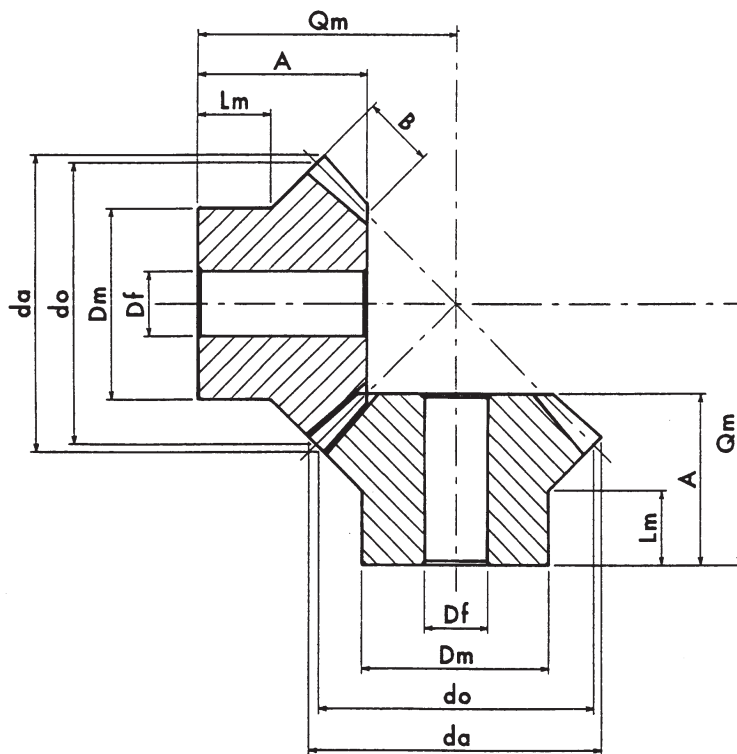

MATERIAL: C 43 STEEL - UNI 7847

M	z	d _o	d _a	D _m	D _f	B	L _m	A	Q _m	Tolerance Q _m	
										min.	max
1	16	16	17	12	4	4	7	12.28	17	-0.020	0.020
	18	18	19	14	4	4	7	12.31	18	-0.020	0.020
	20	20	21	16	4	4.5	8	13.66	20	-0.020	0.020
	22	22	23	18	5	5	8	14.01	21	-0.020	0.020
	25	25	26	20	5	5.5	8	14.87	23	-0.020	0.020
	28	28	29	20	5	6	9	17.74	27	-0.020	0.020
	32	32	33	22	5	7	12	20.44	31	-0.020	0.020
1.5	16	24	25.5	18	6	5.5	10	17.60	25	-0.020	0.020
	18	27	28.5	20	8	6	12	20.47	29	-0.020	0.020
	20	30	31.5	22	8	6.5	12	21.33	31	-0.020	0.020
	22	33	34.5	24	8	7	12	22.19	33	-0.020	0.020
	25	37.5	39	28	8	8	13.5	24.64	37	-0.030	0.030
	28	42	43.5	30	12	9	14	27.10	41	-0.030	0.030
2	32	48	49.5	36	12	10	16	29.82	46	-0.030	0.030
	16	32	34	24	8	7	14	23.92	34	-0.020	0.020
	18	36	38	28	8	7.5	15	25.30	37	-0.030	0.030
	20	40	42	28	8	8	15	24.67	38	-0.030	0.030
	22	44	46	30	12	9	16	28.37	43	-0.030	0.030
	25	50	52	32	12	11	16	29.75	46	-0.030	0.030
	28	56	58	36	12	12	18	34.47	53	-0.030	0.030
2.5	32	64	66	40	14	13	20	38.20	60	-0.030	0.030
	16	40	43	30	12	8	14	25.92	39	-0.030	0.030
	18	45	48	34	12	9	15	28.13	43	-0.030	0.030
	20	50	53	35	12	10	18	32.34	49	-0.030	0.030
	22	55	58	42	14	11	18	33.55	52	-0.030	0.030
	25	62.5	65.5	46	14	12	20	34.50	56	-0.030	0.030
	28	70	73	48	14	14	22	40.17	64	-0.030	0.030
32	80	83	52	16	16	22	43.58	71	-0.030	0.030	

BEVEL GEARS FOR TRANSMISSIONS BETWEEN ORTHOGONAL AXES

Straight teeth Bevel Gears sized in compliance with DIN 3971

Corrected toothing by profile displacement and length-wise crowning of the tooth

Pressure angle: 20°

Gear ratio = 1:1

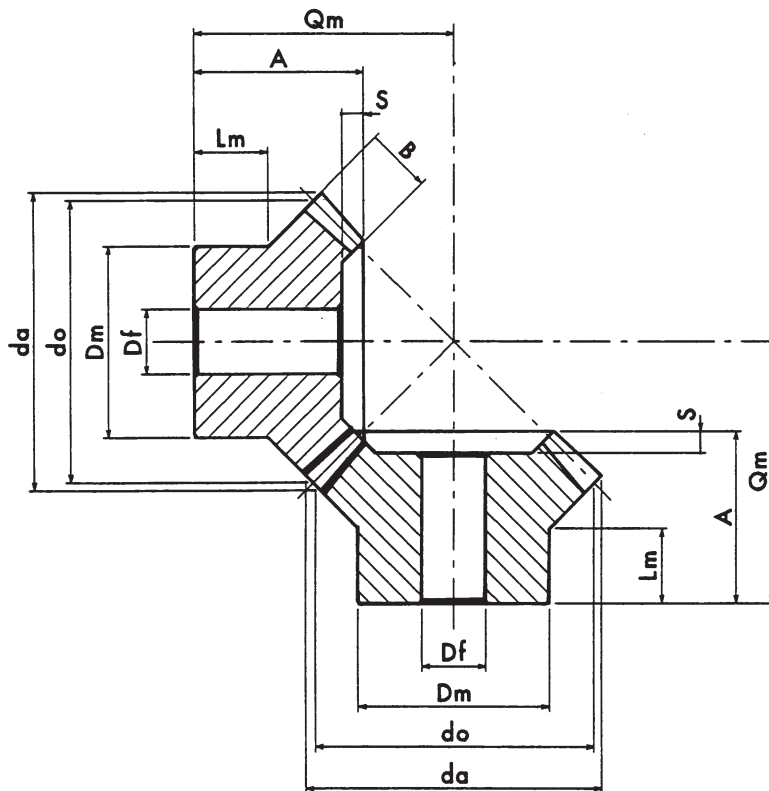

MATERIAL: C 43 STEEL – UNI 7847

M	z	d _o	d _a	D _m	D _f	B	L _m	A	S	Q _m	Tolerance Q _m	
											min.	max
3	16	48	51.5	36	12	12	16	31.85	4	46	-0.030	0.030
	18	54	57.5	40	14	14	18	36.24	4	52	-0.030	0.030
	20	60	63.5	45	14	16	20	37.63	4	55	-0.030	0.030
	22	66	69.5	50	16	16	20	37.70	4	58	-0.030	0.030
	25	75	78.5	50	16	16	24	45.29	4	70	-0.030	0.030
	28	84	87.5	55	16	18	25	48.21	4	76	-0.030	0.030
3.5	32	96	99.5	66	16	20	25	49.63	4	82	-0.040	0.040
	16	56	60	40	14	14	18	35.50	5	52	-0.030	0.030
	18	63	67	45	14	16	18	38.40	5	57	-0.030	0.030
	20	70	74	50	16	18	22	44.30	5	65	-0.030	0.030
	22	77	81	55	16	20	22	46.21	5	69	-0.030	0.030
	25	87.5	91.5	60	16	20	25	48.07	5	76	-0.040	0.040
4	28	98	102	65	16	22	25	50.25	5	82	-0.040	0.040
	32	112	116	75	20	25	25	55.37	5	92	-0.040	0.040
	16	64	69	48	16	15	25	45.50	6	65	-0.030	0.030
	18	72	77	55	16	18	25.5	49.55	6	71	-0.030	0.030
	20	80	85	60	16	20	27	49.97	6	74	-0.030	0.030
	22	88	93	62	16	22	27	55.38	6	82	-0.040	0.040
5	25	100	105	70	20	24	25	54.84	6	86	-0.040	0.040
	28	112	117	80	20	26	25	55.28	6	91	-0.040	0.040
	32	128	133	90	20	28	30	59.75	6	102	-0.040	0.040
	16	80	86	60	16	18	25	50.14	7	75	-0.030	0.030
	18	90	96	63	16	20	30	54.56	7	83	-0.040	0.040
	20	100	106	70	20	22	30	59.99	7	92	-0.040	0.040
5	22	110	116	80	20	24	30	60.41	7	96	-0.040	0.040
	25	125	131	85	20	28	35	69.71	7	110	-0.040	0.040
	28	140	146	90	20	30	38	74.67	7	121	-0.040	0.040
	32	160	166	100	20	32	45	85.16	7	140	-0.040	0.040

BEVEL GEARS FOR TRANSMISSIONS BETWEEN ORTHOGONAL AXES

Straight teeth Bevel Gears sized in compliance with DIN 3971

Corrected toothing by profile displacement and length-wise crowning of the tooth

Pressure angle: 20°

Gear ratio = 1:2

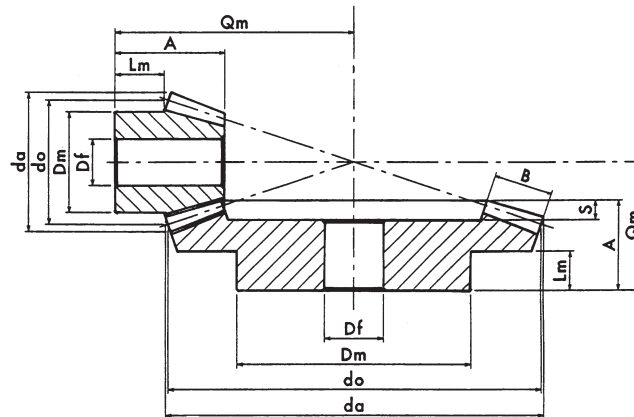

MATERIAL: C 43 STEEL – UNI 7847

M	z	do	da	Dm	Df	B	Lm	A	S	Qm	Tolerance Qm	
											min.	max
1	16	16	18	12	4	6	5	11.78	2	22	-0.020	0.020
	32	32	32	18	5	6	10	18.04		23	-0.020	0.020
1.5	16	24	27	18	8	10	10.5	21.53	3	36	-0.030	0.030
	32	48	48	30	8	10	14	24.97		32	-0.030	0.030
2	16	32	36	24	8	12	11	24.56	4	45	-0.030	0.030
	32	64	64.5	36	12	12	13	28.08		38	-0.030	0.030
2.5	16	40	45.5	32	12	15	15	32.45	5	58	-0.030	0.030
	32	80	80.5	48	16	15	18	37.60		50	-0.030	0.030

Gear ratio = 1:2

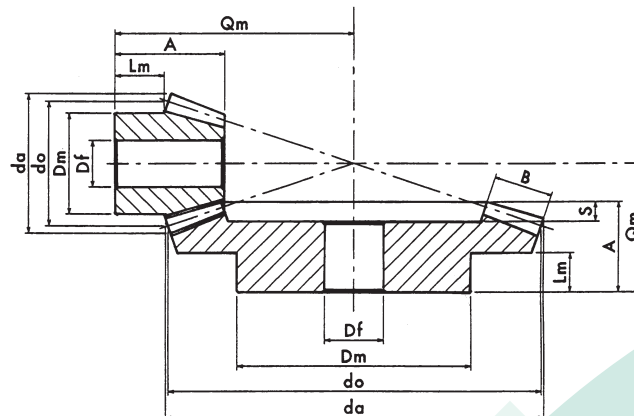

MATERIAL: C 43 STEEL – UNI 7847

M	z	do	da	Dm	Df	B	Lm	A	S	Qm	Tolerance Qm	
											min.	max
3	16	48	55	36	14	18	14	34.34	3	65	-0.040	0.040
	32	96	97	60	14	18	20	40.12		55	-0.040	0.040
3.5	16	56	64	42	14	22	18	42.10	6	77	-0.040	0.040
	32	112	113	70	16	22	22	45.06		62	-0.040	0.040
4	16	64	73	48	14	24	20	45.13	7	86	-0.040	0.040
	32	128	129	80	20	24	25	50.16		70	-0.040	0.040
5	16	80	91	56	16	30	25	59.91	8	111	-0.040	0.040
	32	160	161	100	20	30	30	60.20		85	-0.040	0.040

BEVEL GEARS FOR TRANSMISSIONS BETWEEN ORTHOGONAL AXES

Straight teeth Bevel Gears sized in compliance with DIN 3971

Corrected toothing by profile displacement and length-wise crowning of the tooth

Pressure angle: 20°

Gear ratio = 1:3

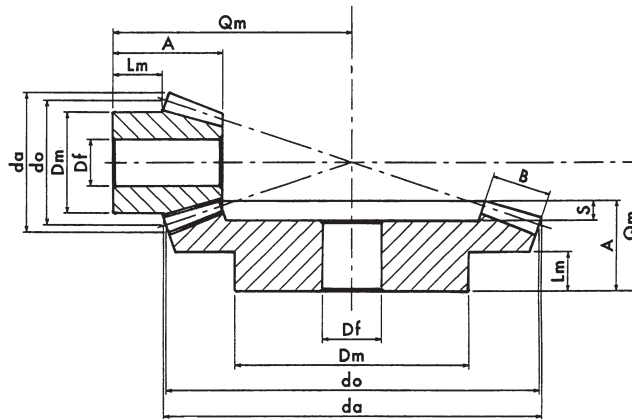

MATERIAL: C 43 STEEL – UNI 7847

M	z	do	da	Dm	Df	B	Lm	A	S	Qm	Tolerance Qm	
											min.	max
1	16	16	18	12	4	8	7.3	15.91	2.5	32	-0.030	0.030
	48	48	47.5	26	8	8	12	21.85		27	-0.030	0.030
1.5	16	24	27.5	18	8	10	9	20.01	3	46	-0.040	0.040
	48	72	71.5	46	12	10	14	25.68		34	-0.040	0.040
2	16	32	37	25	10	14	12.8	27.96	4	62	-0.040	0.040
	48	96	95.5	55	16	14	17	32.11		43	-0.040	0.040
2.5	16	40	46.3	32	12	18	15.6	34.92	5	77	-0.050	0.050
	48	120	119.5	70	20	18	20	40.54		54	-0.050	0.050

Gear ratio = 1:3

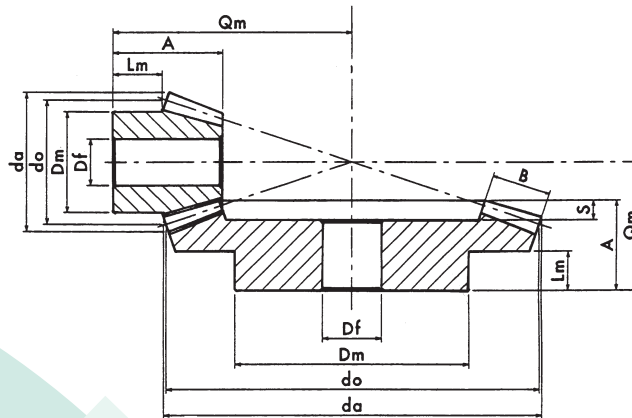

MATERIAL: C 43 STEEL – UNI 7847

M	z	do	da	Dm	Df	B	Lm	A	S	Qm	Tolerance Qm	
											min.	max
3	16	48	55.5	38	14	22	16.3	39.88	3	90	-0.050	0.050
	48	144	144	80	20	22	20	44.96		61	-0.050	0.050
3.5	16	56	65	48	16	25	18.6	44.91	7	104	-0.050	0.050
	48	168	168	90	20	25	25	50.09		69	-0.050	0.050
4	16	64	74.5	52	16	28	18	47.93	7	116	-0.060	0.060
	48	192	192	100	20	28	25	55.22		77	-0.060	0.060
5	16	80	93	63	16	35	27	64.92	9	150	-0.060	0.060
	48	240	240.5	140	20	35	30	64.78		92	-0.060	0.060

BEVEL GEARS FOR TRANSMISSIONS BETWEEN ORTHOGONAL AXES

Straight teeth Bevel Gears sized in compliance with DIN 3971

Corrected toothing by profile displacement and length-wise crowning of the tooth
Pressure angle: 20°

Gear ratio = 1:4

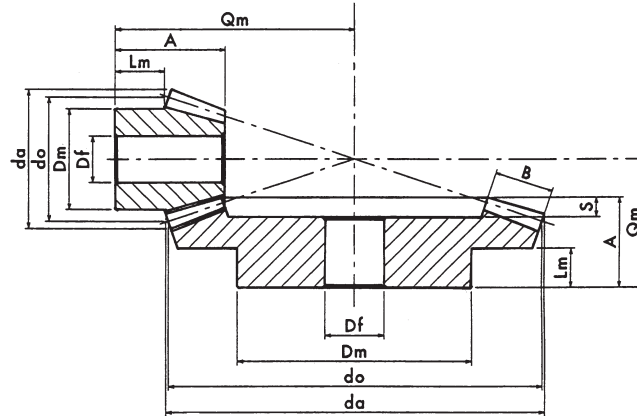

MATERIAL: C 43 STEEL – UNI 7847

M	z	do	da	Dm	Df	B	Lm	A	S	Qm	Tolerance Qm	
											min.	max
1	16	16	18	14	4	10	7.75	17.94	2.5	40	-0.040	0.040
	64	64	63.5	38	8	10	12	21.69		27	-0.040	0.040
1.5	16	24	27.5	20	8	12	12.45	25.08	3	61	-0.050	0.050
	64	96	95.5	56	16	12	15	30.35		39	-0.050	0.050
2	16	32	37	26	10	16	11.2	28.11	4	76	-0.050	0.050
	64	128	127.5	75	16	16	16	32.47		44	-0.050	0.050
2.5	16	40	46.5	32	14	20	14	35.13	5	95	-0.060	0.060
	64	160	159.5	90	20	20	20	40.58		55	-0.060	0.060

Gear ratio = 1:4

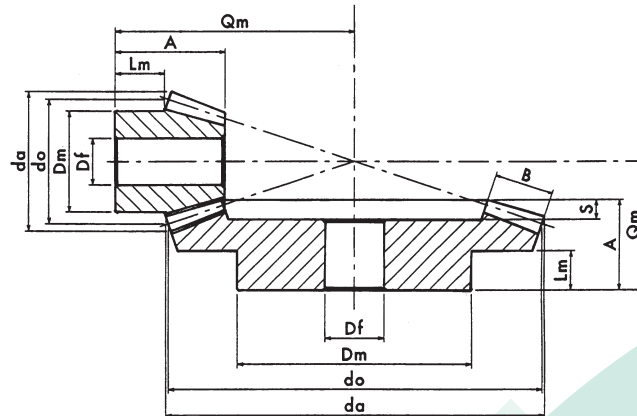

MATERIAL: C 43 STEEL – UNI 7847

M	z	do	da	Dm	Df	B	Lm	A	S	Qm	Tolerance Qm	
											min.	max
3	16	48	56	40	14	25	13	39.12	2	110	-0.060	0.060
	64	192	191.5	100	20	25	20	44.93		62	-0.060	0.060
3.5	16	56	66	48	16	28	15	44.19	3	128	-0.070	0.070
	64	224	223.5	120	20	28	30	59.82		80	-0.070	0.070
4	16	64	75	52	16	32	20.5	54.22	3	150	-0.070	0.070
	64	256	255.5	140	20	32	35	70.93		8	-0.070	0.070
5	16	80	94.5	65	16	36	22.1	60.44	4	184	-0.080	0.080
	64	320	320	170	20	36	35	75.24		10	-0.080	0.080

LOAD-BEARING CAPACITY OF BEVEL GEARS

DESIGNED FOR TRANSMISSION BETWEEN ORTHOGONAL AXES

The mechanical performance or the load-bearing capacity of bevel gears is defined by the twisting moments that the gears are capable of transmitting:

- in the form of dynamic torque, when in motion;
- in the form of static torque, when stationary or moving slowly.

The dynamic torque (M_d) represents the limiting torque yielding due to bending fatigue, whereas the static torque (M_s) indicates the limiting torque at failure by yielding due to tooth bending.

The values declared for both torques are the maximum permitted values and have been tested in compliance with the calculation codes and based on the limiting stress values detailed in the DIN 3991 STANDARDS method C.

The test calculations are valid for a Service Factor (SF) equal to 1 in the absence of data regarding the real operating conditions. **We recommend adopting a safety factor equal to at least 1.5 to adjust the nominal torque to the operating torque.**

LOAD-BEARING CAPACITY OF BEVEL GEARS FOR TRANSMISSIONS BETWEEN ORTHOGONAL AXES

Ratio	M	Z	M_d (Nm)	M_s (Nm)	M	Z	M_d (Nm)	M_s (Nm)
1	16	16	1.35	3.6	16	16	36.8	96
	18	18	1.61	4.25	18	18	48	107
	20	20	2	5.35	20	20	60	158
	22	22	2.5	6.55	22	22	68	182
	25	25	3.2	8.35	25	25	90	235
	28	28	4	10.4	28	28	105	276
	32	32	5.25	13.8	32	32	135	354
1.5	16	16	4.4	11.5	16	16	58	152
	18	18	5.5	14.35	18	18	71	171
	20	20	6.7	17.6	20	20	90	246
	22	22	8	21.10	22	22	111	300
	25	25	10.5	27.6	25	25	140	361
	28	28	13.2	35.	28	28	175	449
	32	32	17.2	40.10	32	32	218	584
2	16	16	10	26.3	16	16	83.6	219
	18	18	12.5	30	18	18	111	290
	20	20	15	39.5	20	20	138	360
	22	22	18.6	48.8	22	22	167	437
	25	25	25.4	65.5	25	25	212	554
	28	28	31.5	82.5	28	28	260	681
	32	32	40	95.15	32	32	327	855
2.5	16	16	18.5	48.5	16	16	159	415
	18	18	24	62	18	18	201	525
	20	20	29.5	68.8	20	20	248	645
	22	22	36	94	22	22	300	782
	25	25	45	118	25	25	394	1029
	28	28	58.5	132	28	28	480	1253
	32	32	76.5	200	32	32	595	1557

Ratio	M	Dynamic torque M_d	Static torque M_s
1:2	1	6.5 Nm	17.2 Nm
	1.5	23.5 Nm	61.5 Nm
	2	52.3 Nm	137 Nm
	2.5	102 Nm	267 Nm
	3	176 Nm	460 Nm
1:3	3.5	287 Nm	745 Nm
	4	416 Nm	1086 Nm
	5	808 Nm	2114 Nm
	1	18.5 Nm	48.5 Nm
	1.5	55 Nm	145 Nm
1:4	2	136 Nm	355 Nm
	2.5	270 Nm	704 Nm
	3	470 Nm	1228 Nm
	3.5	731 Nm	1910 Nm
	4	1074 Nm	2807 Nm
1:5	5	2085 Nm	3508 Nm
	1	40.5 Nm	106 Nm
	1.5	117 Nm	306 Nm
	2	277 Nm	724 Nm
	2.5	540 Nm	1410 Nm
1:6	3	956 Nm	2500 Nm
	3.5	1471 Nm	3845 Nm
	4	2087 Nm	5454 Nm
	5	3926 Nm	10270 Nm

LOAD-BEARING CAPACITY OF BEVEL GEARS FOR TRANSMISSIONS BETWEEN ORTHOGONAL AXES

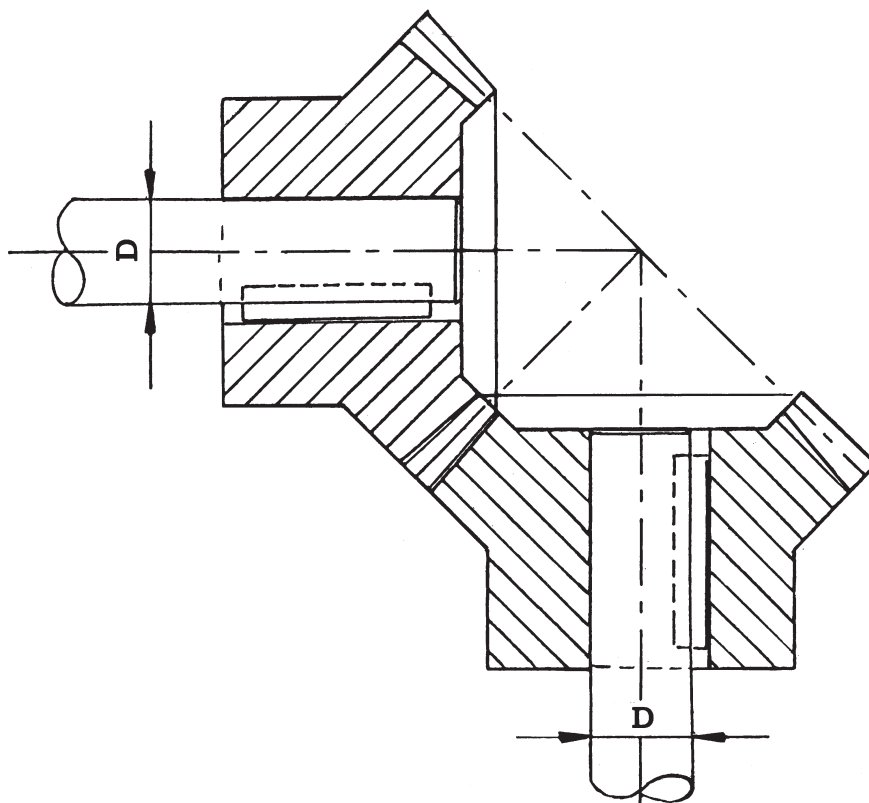

Shaft D = this is the minimum shaft diameter capable of transmitting the dynamic twisting torque with a shear stress equal to 60 N/sq. mm.

Ratio	M	Z	Shaft D	M _s (N _m)	M	Z	M _d (N _m)	Shaft D
1:1	1	16	4	3.6	3	16	13	96
		18	5	4.25		18	15	107
		20	5	5.35		20	16	158
		22	5	6.55		22	16	182
		25	6	8.35		25	18	235
		28	6	10.4		28	19	276
	32	7	13.8	32	20	354		
	1.5	16	7	11.5	3.5	16	15	152
		18	7	14.35		18	17	171
		20	8	17.6		20	18	246
		22	8	21.1		22	19	300
		25	9	27.6		25	21	361
		28	9	35		28	22	449
	32	10	40.1	32	24	584		
	2	16	9	26.3	4	16	17	219
		18	9	30		18	19	290
		20	10	39.5		20	21	360
		22	11	48.8		22	22	437
		25	12	65.5		25	24	554
		28	13	82.5		28	25	681
	32	14	95.15	32	28	855		
	2.5	16	11	48.5	5	16	22	415
		18	12	62		18	23	525
		20	12	68.8		20	25	645
22		13	94	22		27	782	
25		14	118	25		29	1029	
28		16	132	28		31	1253	
32	17	200	32	34	1557			

LOAD-BEARING CAPACITY OF BEVEL GEARS FOR TRANSMISSIONS BETWEEN ORTHOGONAL AXES

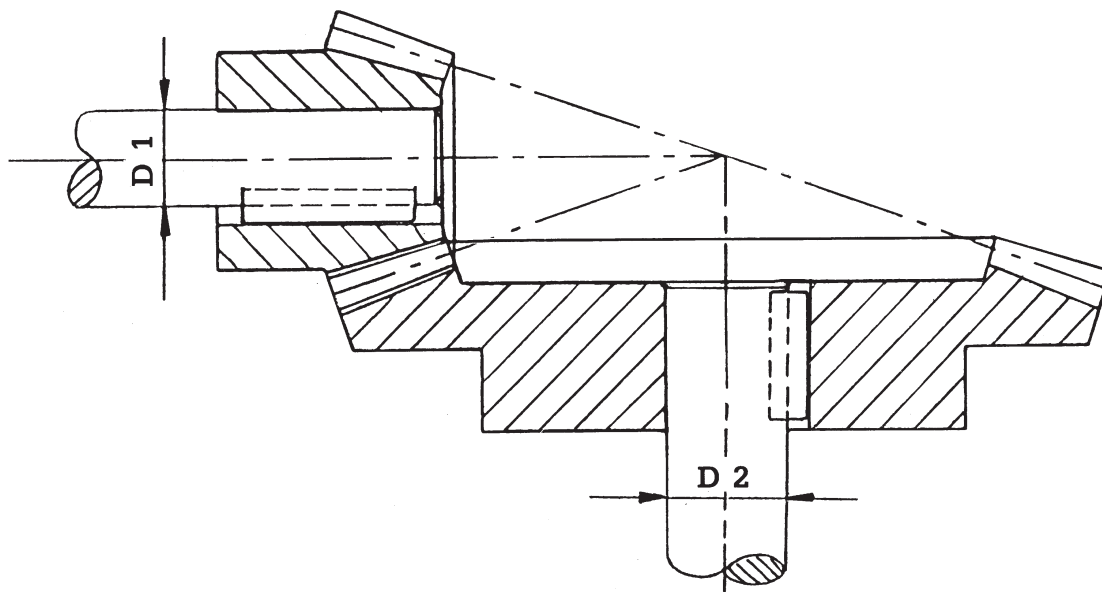

D1 = minimum shaft diameter on sprocket input.

D2 = minimum shaft diameter on wheel

N.B. - The shaft diameters are sized to the output dynamic torque and are tested to withstand a shear stress equal to 60 N/sq. mm.

Ratio	M	Dynamic torque M_d		Static torque M_s		D1	D2
1:2	1	6.5	Nm	17.2	Nm	6	7
	1.5	23.5	Nm	61.5	Nm	9	11
	2	52.3	Nm	137	Nm	12	15
	2.5	102	Nm	267	Nm	15	19
	3	176	Nm	460	Nm	18	22
1:3	3.5	287	Nm	745	Nm	21	26
	4	416	Nm	1086	Nm	24	30
	5	808	Nm	2114	Nm	30	37
	1	18.5	Nm	48.5	Nm	7	11
	1.5	55	Nm	145	Nm	11	15
1:4	2	136	Nm	355	Nm	14	21
	2.5	270	Nm	704	Nm	18	26
	3	470	Nm	1228	Nm	22	31
	3.5	731	Nm	1910	Nm	25	36
	4	1074	Nm	2807	Nm	28	41
1:5	5	2085	Nm	3508	Nm	35	51
	1	40.5	Nm	106	Nm	9	14
	1.5	117	Nm	306	Nm	12	20
	2	277	Nm	724	Nm	16	26
	2.5	540	Nm	1410	Nm	20	33
1:6	3	956	Nm	2500	Nm	25	39
	3.5	1471	Nm	3845	Nm	29	45
	4	2087	Nm	5454	Nm	32	51
	5	3926	Nm	10270	Nm	40	63

LOAD-BEARING CAPACITY OF BEVEL GEARS FOR TRANSMISSIONS BETWEEN ORTHOGONAL AXES WITH SPIRAL TOOTHING

The "GLEASON" system range of bevel gears with spiral tothing is an extension of the range of standard bevel gear pairs with which this range shares the declared intentions and objectives.

The criteria adopted comply as closely as possible with International Standards as regards general sizing and the definition of the geometric features, whereas the choice of the key nominal data has been based on a progression depending on the range of the normal numbers established by the DIN 323 and ISO R3/R17 standards.

The spiral tothing complying with the "GLEASON" system is the result of a specific project designed to achieve optimised functional features compared with the geometric parameters that frequently conflict with each other.

The key sizing for the tothing, in particular refers to the following:

- The choice of a reduced tooth height - Correction by profile displacement - Adoption of a normal pressure angle:

$\alpha_n = 20^\circ$ - The constant tooth bottom gap along the whole tooth surface and other geometric solutions. This series of bevel gear with spiral tothing is designed for general use in plants and in general mechanical applications. The project has been designed therefore, to privilege the mechanical performance normally requested by this sector and special attention has been paid in defining the geometric features that can determine the tooth covering factor and the restraining reactions which determine the load on the bevel gear pair bearings.

By their very nature bevel gears with spiral tothing are designed for a more demanding use compared with that of straight teeth bevel gear pairs therefore, CHIARAVALLI TRASMISSIONI has made available the Company's range of bevel gear pairs with the intention of providing a solution that will be appreciated by the users of this product.

Naturally and in the framework of the Company's traditional technical collaboration with end users, the CHIARAVALLI TRASMISSIONI technical office is available to provide suggestions concerning more specific circumstances and problems.

Directions and angles of forces acting on spiral bevel gears

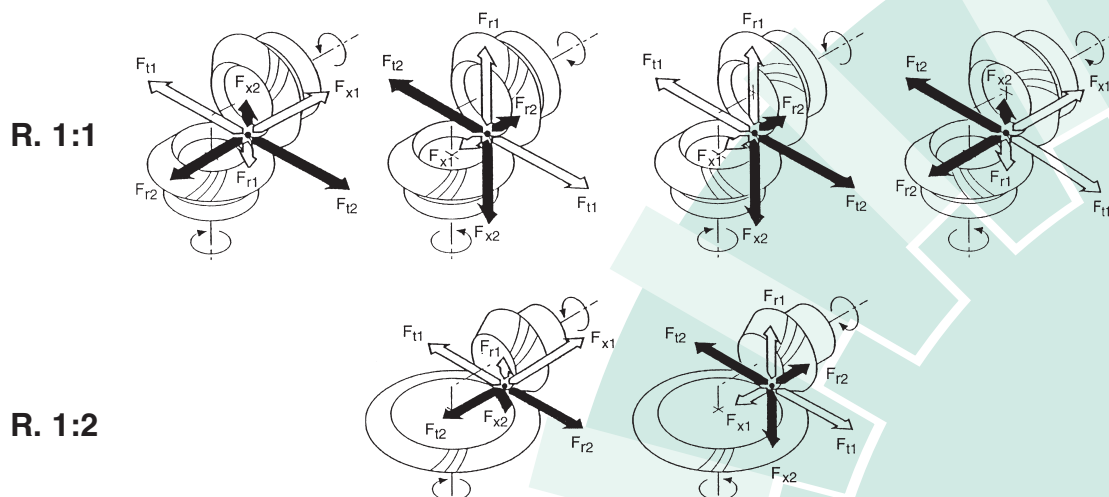

Pinion with left-handed spiral as the drive wheel
Sprocket with right-handed spiral as the driven wheel



"GLEASON" SPIRAL BEVEL GEARS

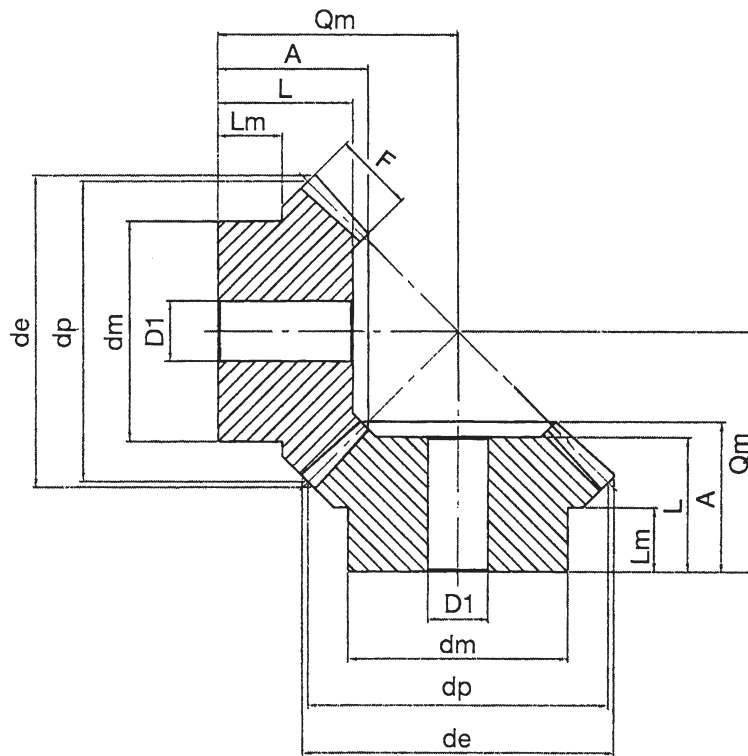

RATIOS 1:1

M	z	dp	dm	D1	F	de	Lm	L	A	Qm
1.5	16	24	18	8	6	25.3	9	16	16.7	24
	20	30	22	8	7	31.3	10	18	19.4	29 -0.05
	25	37.5	28	8	8	38.8	11.5	21	22.5	35 -0.10
	30	45	32	10	10	46.3	11	23	25.1	40
2	16	32	25	10	9	34	9.45	16.9	19.9	29
	20	40	32	10	12	42	11.95	21.7	24.9	36 -0.05
	25	50	40	12	14	52	11.9	24.8	27.4	42 -0.10
	30	60	50	12	16	62	12.95	26.9	29.9	48
2.5	16	40	32	12	10	42.5	13	21.8	24.8	37
	20	50	40	12	12	52.5	16	26.7	30.2	46 -0.05
	25	62.5	50	15	15	65	16	29.9	33.2	53 -0.10
	30	75	55	15	18	77.5	16	31.8	35	59
3	16	48	40	15	12	51	16	25.8	29.4	44
	20	60	45	15	18	63	13.5	30.7	34.5	51 -0.076
	25	75	55	15	20	78	16	33.7	37.5	60 -0.127
	30	90	60	20	22	93	19	35.8	39.5	68
4	16	64	50	15	15	68	17.75	30.8	36	56
	20	80	60	18	17	84	18	32.5	37.5	64 -0.102
	25	100	70	20	21	104	18	35.2	40.4	74 -0.152
	30	120	80	25	25	124	16	38.1	43.2	84
5	16	80	60	20	17	85	18.9	35.5	41.9	68
	20	100	70	20	21	105	18.5	37.7	44.8	78 -0.127
	25	125	90	20	26	130	18.5	41.8	47.8	90 -0.178
	30	150	110	30	32	155	18	45.7	52.5	103

MATERIAL: C 43 UNI 7847

"GLEASON" SPIRAL BEVEL GEARS

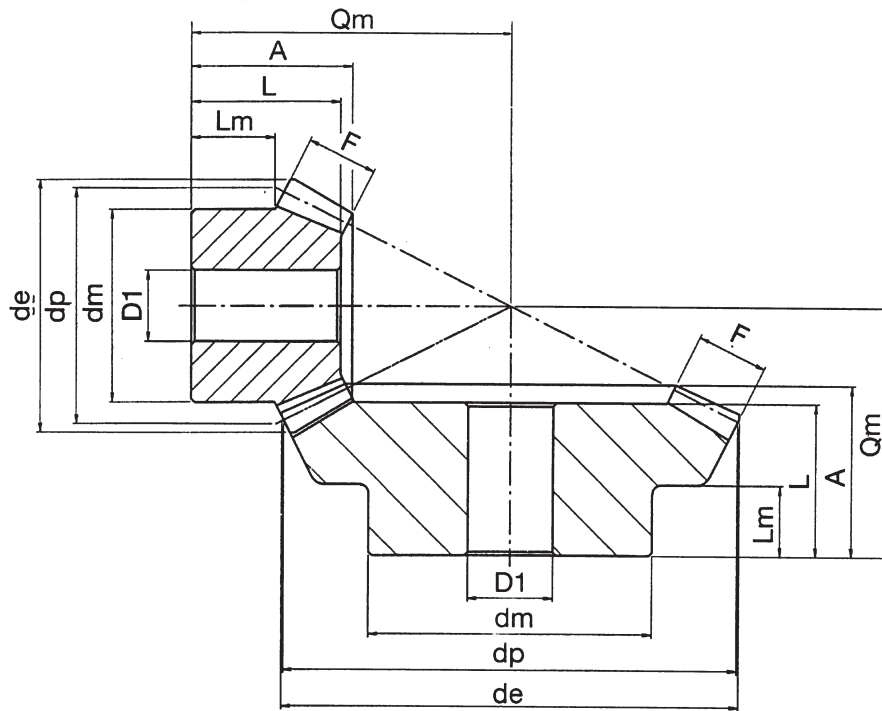

RATIOS 1:2

M	z	dp	dm	D1	F	de	Lm	L	A	Qm	
1.5	16	24	20	10	8	26.50	9.5	17	18.6	35	-0.05 -0.10
	32	48	32	12	8	48.30	10	18	20.0	28	-0.05 -0.10
2	16	32	27	10	10	35.50	11.7	21	22.5	45	-0.05 -0.10
	32	64	40	12	10	64.50	10	21.5	24.1	35	-0.05 -0.10
2.5	16	40	32	12	12	44.50	14	25.1	27.5	56	-0.05 -0.10
	32	80	50	15	12	80.50	15	25.9	29.2	43	-0.05 -0.10
3	16	48	40	15	15	53.50	12	25.2	28.4	62	-0.076 -0.127
	32	96	60	15	15	97.00	15	29.8	34.6	51	-0.076 -0.127
4	16	64	50	20	20	71.50	13.5	32.2	36.2	81	-0.102 -0.152
	32	128	80	20	20	129.00	23	38.7	44.2	66	-0.102 -0.152
5	16	80	60	20	25	89.50	21	45.3	50.0	106	-0.127 -0.178
	32	160	90	25	25	162.00	27	46.8	53.7	81	-0.127 -0.178

MATERIAL: C 43 UNI 7847